

# Fabry-Pérot Laser Diodes (FP): 1100 nm - 1700 nm

## WAVELENGTH

760–840 nm

840–1100 nm

**1100–1700 nm**

1700–2400 nm

2400–2900 nm

2800–6500 nm

6000–14000 nm

High-Power OPT

nanoplus FP are specially designed and characterized to fit your requirements. For more than 25 years, nanoplus has been manufacturing DFB and FP lasers with excellent performance. Our devices operate **reliably** in more than 50,000 installations worldwide.

## Key features:

- BROADBAND
- HIGH-POWER
- SMALL FOOTPRINT

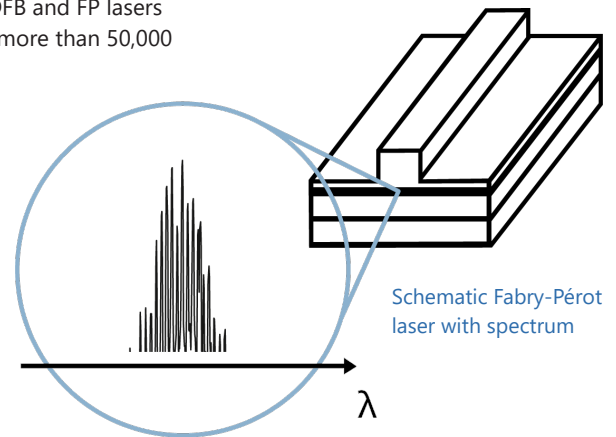

Any **custom wavelength** is possible: You tell us what you need! With our outstanding technology we design any wavelength **between 760 nm and 14000 nm** with an accuracy of +/- 20 nm.

The **output power** of **several mW** yields a strong signal and gives large flexibility to your application. **High power up to 1 W** is available on request **between 1950 nm and 2350 nm**.

We offer **various packaging options**, e. g. several free space housings including TEC and NTC, fiber coupling, **collimation** and **custom designs**. What are your requirements?

**Long-term stability** is one of the principal features customers value about our lasers! Even in **harsh environments** nanoplus devices perform excellently – low maintenance warranted.

**“Do not change your ideas, let us deliver a laser that fits your application.”**

If you require **custom specifications**, please contact us. Nearly 80 % of our devices are more or less customer-specific. As nanoplus is a **fully vertically integrated company**, we control the entire process chain from design to packaging. Both nanoplus production facilities are based in **Germany**. To guarantee consistent product quality we apply a strict and **ISO certified quality management system** at all levels.

Our sales and R&D teams have long-standing experience in developing lasers. They will be pleased to provide advice at any time - rely on us from design stage to product realization as well as after-sales:

**We make market leaders!**



TO5 with cap and AR coated window



# Typical Specifications: 1100 nm - 1700 nm

This data sheet reports performance data of a **sample Fabry-Pérot laser at 1590 nm**, which is representative for the entire wavelength range.

If you need more power, please check our **High-Power Option**: <http://www.nanoplus-usa.com/products/FP>

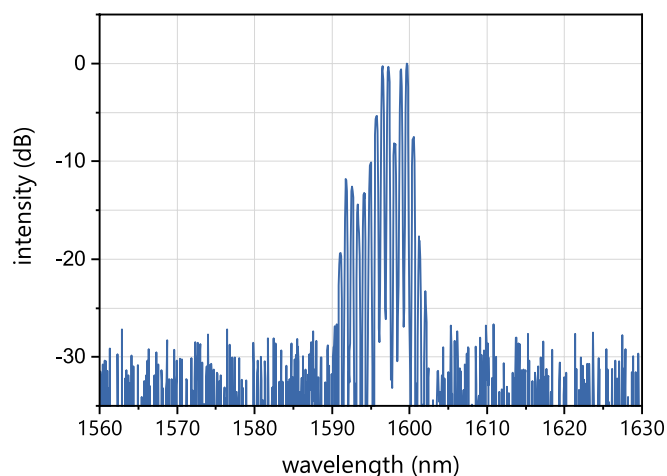

Typical room temperature cw spectrum of a nanoplus FP laser at 1590 nm

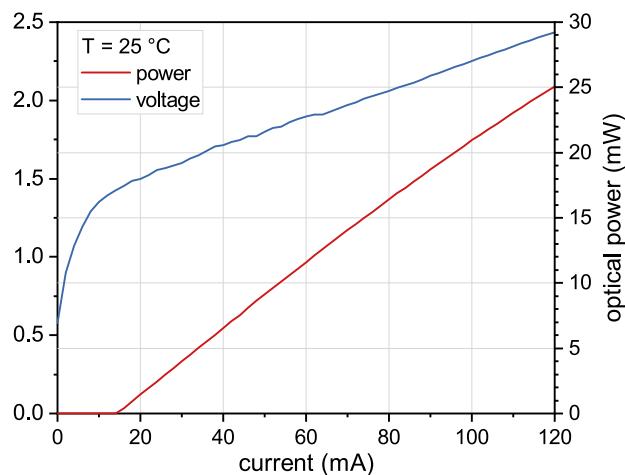

Typical PI and VI curve of a nanoplus FP laser at 1590 nm

electro-optical characteristics	symbol	unit	min.	typ	max.
operating wavelength (at $T_{op}$ , $I_{op}$ )	$\lambda_{op}$	nm	-20	please specify	+20
optical output power (at $\lambda_{op}$ )	$P_{op}$	mW		10	
operating current	$I_{op}$	mA		45	
operating voltage	$V_{op}$	V		2	
threshold current	$I_{th}$	mA		50	
operating chip temperature	$T_{op}$	°C	+20	+25	+50
operating case temperature*	$T_c$	°C	-20	+25	+50
storage temperature*	$T_s$	°C	-40	+20	+80

\* non condensing

## laser packaging options

**TO5 with TEC and NTC, black cap, AR coated window**

**TO56 without TEC or NTC, sealed, window**

**c-mount or other submounts without TEC or NTC**

**butterfly package with TEC and NTC, SM fiber, FC/APC connector**

**chip on carrier without TEC, with NTC**

Technical drawings & accessories are available at: <https://www.nanoplus-usa.com/products/packaging>

Please contact [victor.perez@nanoplus.com](mailto:victor.perez@nanoplus.com) for customized specifications, quotes and further questions.

Visit the [nanoplus website](http://www.nanoplus.com) for technical notes, application samples or literature referrals.

nanoplus America Inc., nanoplus-usa.com, phone: +1-720-453-2454, email: victor.perez@nanoplus.com  
©copyright nanoplus America Inc. 2024, all rights reserved. Technical data is subject to change without notice.